

Expanding Decision Support Systems Outside Company Gates

Petr Bečvář¹, Jiří Hodík², Michal Pěchouček², Josef Psutka³,
Luboš Šmíd⁴ and Jiří Vokřínek²

¹*CertiCon a.s.*

²*Czech Technical University in Prague, Faculty of Electrical Engineering, Department of Cybernetics;*

³*University of West Bohemia, Pilsen;*

⁴*Center of Applied Cybernetics
Czech Republic*

1. Introduction

This chapter presents a set of different decision support systems to demonstrate different ways in which the decision support process can be extended outside a single company.

First, the ExtraPlanT system is introduced. It was originally built as a multi-agent production planning system (ExPlanTech), but later it was enhanced with a wide range of other features. One of them is a set of interfaces for remote access including a thin and thick client, an interface for portable devices and a voice interface based on an automatic speech synthesis. This system demonstrates a possibility of how the decision-making process can be extended – towards the user. A manager on a business trip as well as a tele-worker or a nomad-worker has full access to the decision support system. ExtraPlanT system also contains an enterprise-to-enterprise planning agent and a material-resource-agent. Both agents support cooperation between trusted partners by sharing information in the decision support process. This technology allows an outsourcing company or a material supplier, equipped with a compatible system, to share available capacities and obtain basic planning information.

The second system introduced is called e-Cat. It is designed as a competency register for a Virtual Organization, a consortium or a professional community. This web catalogue system combines centralized and de-centralized elements in order to preserve member's autonomy while ensuring data consistency and safety of the community. Emphasis is put on the intelligent match of searched and available competencies. If the exact match cannot be reached, a generalization and a specialization can be used to find a suitable partner. The main use of the e-Cat system is in formation and evolution of Virtual Organization.

The last system is called DSS (Decision Support System) and it is directly focused on the operational management of Virtual Organizations. It supports the Virtual Organization manager by simulating possible future performances of the organization. The embedded scheduler provides the user with a wide range of additional features: impending deviations alerting, suggestions of local adaptation, alternative of Virtual Organization configuration analyzer, what-if analysis, and other.

Source: Decision Support Systems, Book edited by: Chiang S. Jao,
ISBN 978-953-7619-64-0, pp. 406, January 2010, INTECH, Croatia, downloaded from SCIYO.COM

2. ExtraPlanT multi-agent system for production and supply chain planning

Besides collecting and presenting data to the user, the modern decision support systems also provide extensive analysis of these data. Such analysis can include simulation, knowledge-based analysis, data mining, and other approaches based on artificial intelligence. These modern approaches require a great deal of computer resources and direct access to company data sources, which can be a drawback in modern, de-centralized and nomadic environment. A straightforward solution to this problem is an application server that runs all the analysis within company gates and user interface clients that make the results accessible worldwide (Shen at al., 2005). These clients can be *thick* clients which must be installed by the user or *thin* clients which run in the user's web browser.

For users within the enterprise, *thick client* technology is usually used: the unformatted results are transferred and presented by a client program running on a personal computer. *Thin client* technology is more suitable for users outside the enterprise, so that the results are formatted by the application server into a presentable format (e.g. HTML, ECMA Script¹ or ActionScript²) and presented to the user by a standardized device.

The potential of thin and thick client approach is demonstrated in this section using an example of ExtraPlanT decision support system and their Extra-enterprise and Enterprise-to-enterprise features (Bečvář at al., 2007).

While original ExtraPlanT interfaces adhered to the concept of thin client, contemporary interfaces usually use Rich Internet Application technique to enrich thin clients with the features originally common to thick clients.

2.1 Internal system architecture

The ExtraPlanT decision support system has been developed by Gerstner Laboratory at the Czech Technical University in Prague, the CertiCon Company³.

ExtraPlanT is an extension of ExPlanTech (Pěchouček at al., 2002b) intra-enterprise production scheduling in *Small and Medium-sized Enterprises* (SMEs) with project-oriented production. ExPlanTech implements a ProPlanT (Mařík at al. 2000) reference multi-agent architecture. The system is composed of non-trivial agents providing different system functionality. The number of agents changes only to reflect changes in the factory configuration or to add system features.

The basic set of agents that have to be always present in ExPlanTech system is called *Core Agents* and it implements planning and resource management. The purpose of this core functionality is to aid a human user in determining the resources needed for a particular project, creating production plans, and balancing the utilization of internal resources, and also to warn the user if there are insufficient resources for the existing project.

The Core Agents can be extended by a number of optional *Additional Agents* implementing other related features. In ExPlanTech project, these agents were responsible for interaction with legacy factory systems, and they provided thick client user interfaces.

The Set of Additional Agents was largely extended within ExtraPlanT project – three types of agents were added:

- Agents for performance measurement and supervision

¹ <http://www.ecma-international.org/publications/standards/Ecma-262.htm>

² <http://www.adobe.com/devnet/actionsript/>

³ <http://www.certicon.cz/>

- Agents providing various kinds of user interfaces
- Agents for extra enterprise cooperation.

An example of the configuration is depicted in Figure 1.

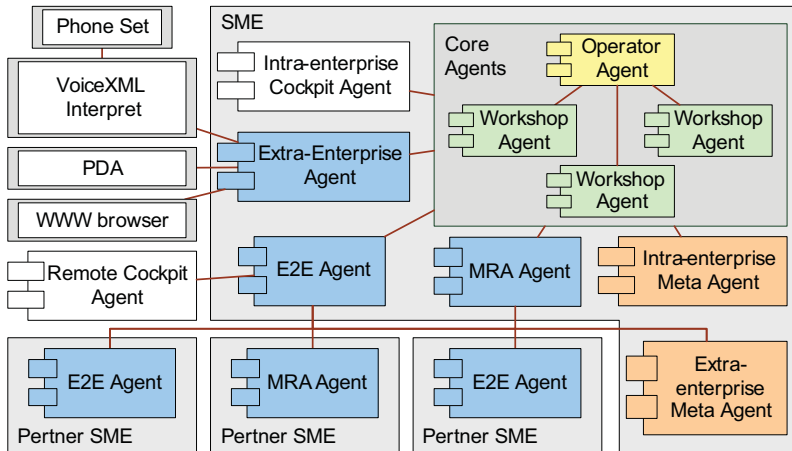

Fig. 1. Simplified architecture of the ExtraPlanT system.

The first group is represented by the *Intra-Enterprise Meta-Agent*, dedicated to the visualization and analysis of medium and long-term manufacturing processes (Hodík at al., 2005) and *Extra-enterprise Meta-Agent* for the analysis of external cooperation with suppliers and partners.

The second group of Additional Agents provides a variety of possibilities for the user to interact with the decision support system. It implements several versions of thin and thick clients mentioned in Section 2 and further described in Section 2.2.

The third group contains agents for extra enterprise cooperation. In ExtraPlanT system *Material Resource Management Agent* and *Enterprise-to-Enterprise Agent* were developed to help optimizing material resource manipulation and supply chain relationships (see Section 2.3) (Pěchouček at al., 2005).

2.2 Extra-enterprise user interfaces

A significant part of ExtraPlanT project focused on the availability of decision support outside the company network. At the dawn of networked or virtual organizations, nomadic working and globalized economy, it was clear that managers of even small enterprises need to make decisions anywhere and with proper support. The project attempted to exploit all the technology available at that time to provide decision support in such scenarios. The set of use cases also included an option to offer a limited version of this access to a trusted partner or customer to be able to track the work of their order.

The thin client technology consists of the *Extra-Enterprise Agent* (EEA) (Hodík at al., 2005) that acquires data from Core Agents and relays them to a WEB-tier of Java EE⁴ multi-tiered application running an application server. The EEA is a member of the agent community

⁴ <http://java.sun.com/javae/index.jsp>

and it uses an asynchronous inter-agent messaging to communicate with other agents. *FIPA Request Protocol* is used to query other agents periodically for new data and *FIPA Subscribe Protocol*⁵ is used when the other agent is able to inform EEA autonomously about data changes.

The WEB-tier converts data into HTML pages etc., thus making them viewable using standard devices. Four versions of thin client were implemented: standard HTML output to be viewed by WWW browser, simplified HTML layout for PDA devices (XHTML was not an adopted standard yet), WML cards to be viewed by WAP enabled cell phones (an example of technology that faded away before becoming widely used), and VoiceXML to be processed by VoiceXML Interpreter and accessed by common telephone set (see section 2.4).

The thick client technology (also named *Remote Cockpit Agent*) assumes an installation of dedicated software on a user's computer, but it later provides the user with a more convenient way to handle the decision support system. Strong emphasis is put on the security of extra-enterprise communication: public key cryptography in common with the secure JADE platform and HTTPS protocol is employed to provide the maximal security level.

2.3 Agents for Enterprise-to-Enterprise cooperation

Agents for enterprise-to-enterprise (E2E) cooperation represent an early attempt to involve external partners directly into the decision support process. Unlike the concept of virtual organizations introduced below, the E2E solution used in ExtraPlanT is mainly viewed from the point of view of a single company. Also, the whole solution requires the installation of dedicated software on the application server of each company involved in the cooperation.

Enterprise-to-enterprise Agent

This agent connects ExtraPlanT system to compatible external software systems. The main mission of the E2E Agent is to augment the decision support process by proactively exchanging data with extra enterprise partners. This technique is focused on finding possibilities of tasks outsourcing in the case of exhausted local resources and on advertising free local capacities to the cooperators.

On the enterprise-to-enterprise level, each partner is represented by one agent and these agents connect together on a peer-to-peer basis. The background of E2E Agents is hidden for the others so that the cooperation does not depend on a particular infrastructure used by each partner.

Knowledge-based social model helps E2E Agents to propose which partner could best cover the needs of the company. The agent can take into account various aspects of cooperation and make decision upon many criteria (such as reputation, history of cooperation, recommendation, due dates, price, expected quality, etc.). This model is continuously updated with every new contract or information.

Material Resource Agent

Material Resource Agent (MRA) was designed to support the decision process in another major task of supply chain management. A material resource handling differs from free capacities sharing (material resources are storable, often requiring precise specification...) and, therefore, a dedicated agent with different control algorithm and data access is required.

⁵ <http://www.fipa.org/>

The material resource handling is implemented on both intra-enterprise and enterprise-to-enterprise level. On the intra-enterprise level, the MRA is equipped with an adequate user interface or a database connection to be able to obtain data from case specific data sources. On the enterprise-to-enterprise level, the communication abilities have been enhanced to allow exchange of relevant data in a community of MRA and E2E Agents.

2.4 Voice interface

The ExtraPlanT telephony interface was implemented using a VoiceXML technology. VoiceXML is a standard⁶ that allows dividing telephony application into two independent parts by defining the interface between them – the VoiceXML language. The parts are (i) low-level speech recognition and synthesis engine (*VoiceXML Interpreter*) and (ii) high-level domain-dependent application. The two modules and their interaction are depicted in Figure 2.

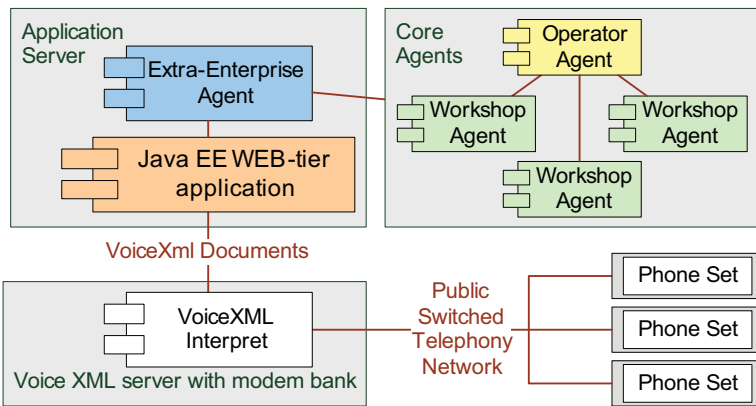

Fig. 2. Structure of the telephony interface and its connection to ExtraPlanT Core Agents.

The ExtraPlanT telephony interface was implemented using a VoiceXML Interpreter (Šmídl at al., 2002), which is available in the Center of Applied Cybernetics at the University of West Bohemia in Pilsen⁷. This interpreter uses an engine for speech recognition and synthesis (Müller at al., 2000) which was developed in the Department of Cybernetics at the same university in cooperation with the SpeechTech⁸ company. The engine contains a text-to-speech module (Matoušek at al., 2004) that produces intelligible and natural speech. The high-level application does not need to be concerned with speech processing and instead focuses on the structure of dialogs and transferred data. The interaction between the user and the system is viewed as a sequence of dialogs described by the VoiceXML documents. Dialogs can feature synthesized speech, digitized audio, recognition of spoken speech and DTMF (Dual-tone multifrequency, also known as Touch Tone) key input. An example of a VoiceXML Document is depicted in Figure 3.

⁶ <http://www.w3.org/TR/voicexml/>

⁷ <http://ui.kky.zcu.cz/en>

⁸ <http://speechtech.cz/index-en.php>

```

<?xml version="1.0" encoding="UTF-8" ?>
<vxml version="1.0">

  <menu id="main_menu">
    <prompt count="1">
      Welcome to voice XML application. Press one for speech synthesis demo,
      Two for speech input demo, three for touch tone input demo or hash for exit.
    </prompt>
    <choice DTMF="1" next="Synthesis.vxml"/>
    <choice DTMF="2" next="Speech.vxml"/>
    <choice DTMF="3" next="DTMF.vxml"/>
    <choice DTMF="#" next="#exit"/>
    <catch event="noinput nomatch">
      <prompt>
        Input was not recognized. Please press one for speech synthesis demo,
        two for speech input demo, three for touch tone input demo or hash for exit.
      </prompt>
    </catch>
  </menu>

  <form id="exit">
    <block>
      <prompt> End of the voice XML application. Goodbye. </prompt>
      <disconnect />
    </block>
  </form>

</vxml>

```

Fig. 3. Example of a VoiceXML document as used in the telephony interface.

A telephony interface, like any other type of interface, has certain advantages and drawbacks. The main advantage is its accessibility in situations when a computer cannot be used. Interaction with the system is natural and does not require any special training.

However, speech has certain disadvantages when used as a computer system's output. The speech is sequential and time-consuming, meaning that the user hears pieces of information one at a time, requiring him or her to remember all the previous messages. If a large amount of information is necessary for a particular decision, it is, therefore, difficult to ensure that the user remembers everything at the appropriate moment (Balentine & Morgan, 1999).

Two techniques have been developed to help mitigate this disadvantage: *Dynamic Prompt Wording* and the *Two-level Communication Model*.

Dynamic Prompt Wording

Every user who has some frequent experience with common telephony applications (e.g. phone banking) becomes annoyed with lengthy interaction. Explanations and polite phrases that are useful during the first interactions soon become useless and obstructing. A telephony interface of decision support systems is used daily by a small group of trained users. To optimize the descriptiveness of the machine output according to a user's experience, the *Dynamic Prompt Wording* technology has been developed.

The wording of each utterance is selected dynamically from among several possible versions. The longest, most detailed versions are used for novice users. For more experienced users, the interface chooses a shorter version, without explanations or polite phrases. All versions of all utterances used in one dialog are defined in a XML file and they

are selected dynamically according to the user's experience with the particular dialog (Bečvář et al., 2004).

Two-level Communication Model

Spoken presentation, unlike graphical interface, is not able to display information in parallel. While a graphical interface can simply display a graph and let the user select from it any desired information, the user of speech interface has to receive pieces of information one by one (Balentine & Morgan, 1999).

Two possible solutions are available: (i) to transmit all data and let the user record and analyze them or (ii) to analyze the data on the server side and transmit only the desired conclusion.

The *Two-level Communication Model* presumes the use of both solutions. If approach (i) is used, we refer to it as the *Fact-finding Mode*, while approach (ii) is called the *Analytical Mode* of the interface.

The Analytical Mode requires a new component, called the *Analytical Module*, which uses the knowledge based approach to estimate which information is important for the user, to obtain relevant data and to present the information early in the conversation in the form of short summaries (Bečvář et al., 2007).

If the problem is detected, further information is usually necessary in order to solve it. The telephony interface then switches to the *Fact-finding Mode*, which presumes that the user is prepared to record the received information for later analysis. In the *Fact-finding Mode* the interface simply transmits all the facts that are potentially relevant.

3. Virtual organizations

SMEs usually cannot satisfy complex customer needs on their own, so collaboration is needed to cover all the business aspects (Boughzala & Zacklad, 1999) (Říha et al., 2002). To increase their competitiveness and to gain more business opportunities, SMEs form alliances.

The set of individual partners (SMEs) that share information about their resources, all agreeing to form possible coalitions, is called *alliance*. The alliance is regarded as a long-term cooperation agreement among the partners. A *coalition* is defined as a set of partners who agreed to fulfill a single, well-specified goal. A coalition, unlike an alliance, is thus usually regarded as a short-term agreement between collaborative partners (Pěchouček et al., 2002a). In contemporary business terms, the coalition of SMEs is commonly called Virtual Organization (VO).

The VO is a kind of networked organization, having been defined many times. Common key-terms related to the VO are: (i) specific form of a network organization, (ii) formed by autonomous and mutually independent partners, (iii) single body towards the customer, (iv) dissolved after its mission fulfillment and (v) allowing individual partners to concentrate on their core competencies. Some of definitions also require the following features for the networked organization to be accepted as a VO: (vi) sharing risk with partners, and (vii) use of information technology for the organization coordination.

The *VO lifecycle* (Camarinha-Matos & Afsarmanesh, 1998) consists of four main phases: *creation*, *operation*, *evolution* (or adaptation) and *dissolution*, as shown in Figure 4.

The decision making process in the environment of a VO differs from the same process in a closed, centralized organization in several important ways. In a closed organization the manager has full access to internal information of the managed units as well as full control

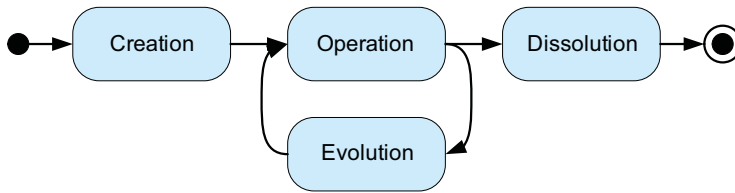

Fig. 4. VO life-cycle

over them. The VO manager is limited by the concluded contract and the willingness of managed VO members to cooperate, provide information and update the contracts. Information and communication systems are crucial for effective decision making in VO (Adesta, 2005). Although standard tools (web sites, emails, databases, etc.) work well, they are separate and do not offer a possibility of integrating knowledge from various sources and of ensuring common and consistent view for all partners. Section 4 describes a profile catalog tool mainly intended for the creation and evolution phase of VO, while Section 5 deals with a simulation tool usable in the creation, operation and evolution phase.

4. e-Cat – system for competency management in virtual organization

Unlike ExtraPlanT, the e-Cat system was intended for use in networked environment of alliance of SMEs from the beginning. As another example of early systems, it focused on a single aspect of virtual organization and on a single stage of virtual organization life cycle. e-Cat is a prototype of a tool designed to support partner search during the creation or evolution phase of VO lifecycle by proper and consistent profile and competency management. If SMEs are able to quickly find a partner with appropriate abilities, competencies and services, they can together collaboratively cover new business opportunities.

4.1 Competency management

Since the terms “competency”, “competency class”, “competency instance” and “profile” are used in several slightly different meanings, it is important to summarize the competency management terminology (Biesalski, 2003).

For the purpose of e-Cat the definitions presented in (Hodík et al., 2009) are used:

- **Competency** is an ability to perform business processes which are supported by necessary available resources, practices and activities, allowing the organization to offer products/services.
- **Competency class** defines the existence of the competency in the world; it distinguishes it from other existing competencies and defines relations to them. Competency class may be extended by the definition of means used to measure the level and robustness of the competency. If a class is not specific enough, specializing classes may exist. Thus, every competency class can have its generalizing and specializing class(es).
- **Competency instance** always refers exactly to one competency class and to one subject. If the competency class defines Competency Evidences, the competency instance can optionally assign values to them.
- **Profile of subject** contains two main elements: (i) general information about the partner, and (ii) a set of competency instances derived from the competency classes.

4.2 The e-Cat system

The e-Cat is an agent-based prototype of a tool for competency management in alliances of SMEs. The technology used is based on a distributed set of agents, representing individual members supported by centralized elements. Such a hybrid peer-to-peer network architecture (Friese et al., 2002) enables effective cooperation in a heterogeneous distributed environment where agents ensure maximal independence between alliance members and private knowledge preservation.

Data are stored and exchanged in the XML format. The schema describing competency classes and profiles is based on HR-XML⁹ schema designed for competency description in human resources management. Some elements that are meaningful only for human resource management have been removed, and the schema was extended by means of defining taxonomy of competencies.

For each competency class, a set of generalizing, specializing and related competencies can be defined. Cycles are not allowed. If the competency class has no generalizing competency, it is one of the *roots* of taxonomy structure. If the competency class has multiple generalizing competencies, it will be displayed on multiple positions in taxonomy trees in the user interface.

Alliance members provide other members with its profile containing their competencies. Each competency in the profile is inherited from a competency class defined in the Catalogue of Competency Classes. The user interface to the system is provided by thin clients through ordinary web browsers. Some screenshots of the interfaces can be found in Figure 5.

The e-Cat consists of following subsystems:

- **Distributed Profile Catalogue** keeps, manages and distributes members' profiles. Each member is responsible for keeping his profile up-to-date and consistent with set of competency classes, shared within the alliance. e-Cat system distributes the profile to other members and provides read-only access to profiles of other members. The catalogue is equipped with an intelligent search tool able to use generalizing and specializing competencies when an exact match cannot be found.
- **Catalogue of Competency Classes** provides partners with a list of competency classes that can be advertised through e-Cat. Each class is defined by their exact description, attributes and location within competency taxonomy. The Catalogue of Competency Classes is a centralized element, maintained by a competency expert. It ensures coherence in the common schema of competencies.
- **Members Registration Authority** is another centralized element that maintains a list of members of the alliance. For each member, all the data necessary for identification in the real and virtual environment are kept. The centralization allows the alliance management to control the members entering and leaving the community and prevents a member from pretending to act as another company.

These systems are implemented by three types of agents: *Members Registration Authority Agent*, *Catalogue of Competency Classes Agent* and *SME Agent*. The first two agents with appropriate user interfaces are intended to be deployed on alliance management servers and maintained by responsible experts of alliance support institutions. Each alliance member is represented by single SME Agent and each agent may be deployed on member's servers (see Figure 6). To increase the utilization of computer resources, several members can share a

⁹ <http://ns.hr-xml.org/23/HR-XML-23/CPO/Competencies.html>

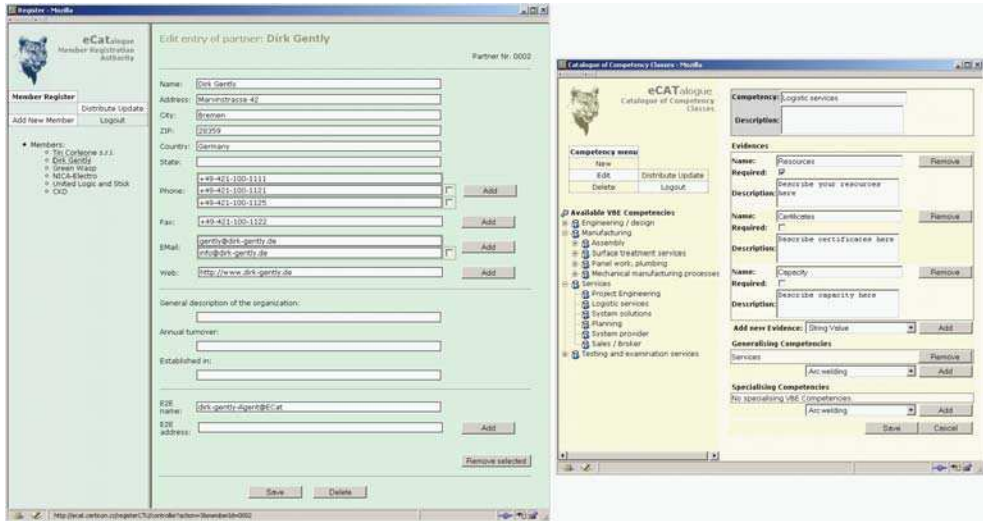

Fig. 5. Screenshots of the e-Cat user interfaces

single server and deploy their agents on a third-party computer. SME Agents can also be deployed on alliance management servers. In an extreme case, the distributed part of the catalogue can be omitted and the whole system can run on a single central server.

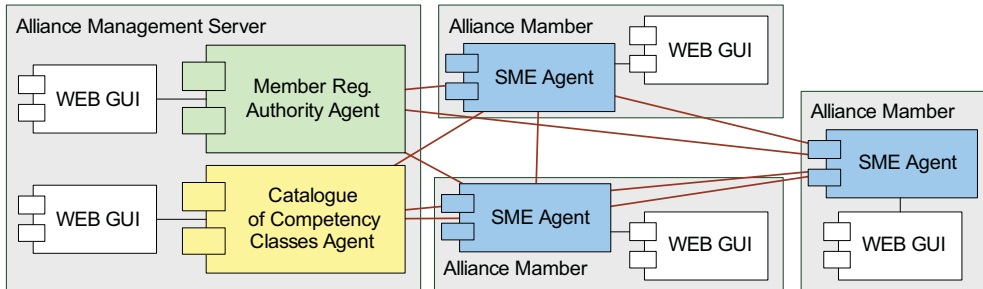

Fig. 6. Deployment diagram of centralized and decentralized elements of e-Cat

e-Cat system is designed to be robust against failure of any of its agent or communication link. Each agent maintains local data cache, which is used during the inaccessibility of another agent, and which is replaced by actual data as soon as the connection is restored.

Centralized elements provide alliance members with: (i) ensuring the common understanding of competencies within the whole alliance, and (ii) maintaining identification information of alliance and thus maintaining the security measures against intruders or alliance members with malicious behavior.

4.3 Usage scenario

Several user scenarios were considered to be performed with e-Cat:

- **Joining the alliance and creating new profile.** A new member of the alliance installs required software on the company server or another available server. The newly

installed system requires addresses of Members Registration Authority Agent and Catalogue of Competency Classes Agent to operate. When the new installation of SME Agent is finished, the company can be included in Members Registration Authority and thus be added to the alliance. From now on, agents of other alliance members can obtain the address of a new agent from the Members Registration Authority so that they can exchange the profile information.

- **Announcing a competency.** When an alliance member decides to offer some services to other members, the competency class for such services is instantiated in its profile. The appropriate competency class is found in Catalogue of Competency Classes. If the proper class does not exist in the catalogue, it can be added in cooperation with the manager of Catalogue of Competency Classes, or a generalizing competency can be used.
- **Creating a new competency.** When a request for adding a new competency class to the catalogue appears, the competency expert reviews the request and decides whether or not to accept it and adapt the catalogue. SME Agents are automatically notified once the catalogue is updated.
- **Looking for a provider of a competency.** The search engine of the e-Cat system offers various attributes for finding a potential partner in the alliance. If the search result is unsatisfactory, the user can decide to use the taxonomy structure to find a partner providing generalizing or specializing competency.

4.4 Exploitation

The prototype of the e-Cat system was used by CertiCon Corporation to develop an IRIS system – a competency catalogue portal application. The IRIS system was developed for a CertiCon customer to be a central point of an alliance of SMEs carrying business in IC design. In contrast to e-Cat, the IRIS system is not based on de-centralized multi-agent architecture but utilizes classical database and application server architecture.

IRIS system uses a concept of competency classes and competency instances that proved successful in e-Cat system. It is extended by a set of other features like more advanced competency search and extended profile of alliance member. IRIS system is integrated with Typo3¹⁰ a content management system that allows each member to enrich their profile with any desired content.

5. DSS – decision support system for simulation of virtual organization performance

The Decision Support System (DSS)¹¹ concentrates on supporting operational management of VO. The user of the DSS is the VO manager/coordinator. The DSS may be used simultaneously with the e-Cat system or independent of it – these two systems are complementary. The dominant lifecycle phase for using the DSS is the evolution phase, but it may significantly facilitate the decision making process during the creation as well as operation phases. The place for use of the DSS in the VO lifecycle is highlighted in Figure 7.

¹⁰ <http://typo3.org/>

¹¹ The internal name of this activity was e-Dog (electronic Decision Optimization Guide) but it was not published as the official one. Therefore, there is no special name for this decision support system.

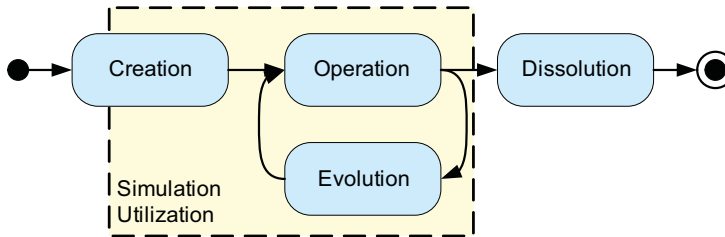

Fig. 7. Scope of the simulation in the VO life-cycle

DSS allows the VO manager to proactively detect and evaluate changes in the VO operations, and it provides suggestions for the adaptations. The simulation analysis supports this process as well as suggests answers to “what-if questions” before the change is applied or the explored situation has occurred (Miller et al., 2002). Such simulation also supports the VO manager in discovering potential bottlenecks and the possibilities of their removing.

The core of DSS is formed by a VO operations simulator based on agent-based rescheduling concept, originally developed for intra-enterprise scheduling in the ExPlanTech project. The original concept is modified so that each VO member is represented by a set of ExPlanTech Core “Workshop” Agents; each of the agents represents one production unit, also known as the competency cell (Neubert et al. 2001). The agent-based core of the system is supplemented by a group of tools for management of VO configurations, plans, and schedules, interfaces for online gathering of VO operational data from dedicated automated tools, tools for configurations of VO operation simulation as well as its (re)scheduling, and analytical tools for evaluation of the alternative VO configurations and schedules. The DSS architecture and prototype implementation are described in more detail in (Hodík & Stach, 2007).

5.1 Virtual organization management toolkit

DSS is a component of the Organization Management toolkit (VOM), which is a complex system for management of distributed workflows of the VOs. The VOM toolkit consists of several interconnected subsystems:

- **VOMod** (VO-Model) is a core maintaining the VO configuration, including the definition of its task and consortium.
- **SID** (Supporting Indicator Definition) is a tool for managing a configuration of performance indicators necessary to be monitored during the VO lifecycle.
- **DI3** (Distributed Indicator Information Integrator) is a technology for collection of VO operational data (according to the defined performance indicators) distributed among the VO members.
- **MAF** (Monitor and Finance) is a tool for analyzing the measurements of the current state of the VO as it is.
- **DSS** (Decision Support System) is a tool for the simulation of the possible VO performance according to the actual state of the VO configuration and the configuration given by the VO manager.

Figure 8 presents VOM components and their high-level dependencies (Hodík et al., 2007) (Negretto et al., 2008).

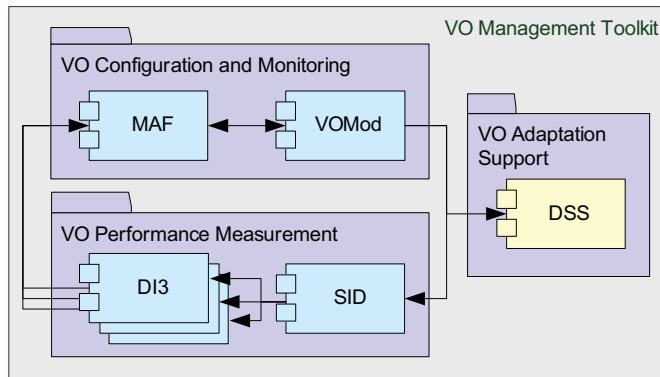

Fig. 8. Architecture of the Virtual Organization Management Toolkit

DSS may be run as a stand-alone application. If connected to the other VOM toolkit components, it utilizes operational data as they are collected and stored by it. Otherwise, such (as well as virtual) data has to be provided manually.

5.2 Simulation based what-if-analysis

The what-if-analysis provided by DSS is primarily based on current state of the VO, and provide an outlook on possible future progress. For the decision making process, the what-if-analysis is an important tool to prove the hypothesis and intended actions before putting them into operation. The simulation runs according the VO state and allows several configurations of the constraints to the simulated future. The three main steps of the what-if-analysis are:

1. Simulation Configuration
2. Simulated VO Performance (the simulation itself)
3. Simulation Evaluation

During the simulated VO performance, the simulated runs are influenced by defined constraints, and the rescheduling invoked by them is executed as many times as configured. Finally, the results are collected and evaluated. For the activity flow of the simulation based what-if-analysis see Figure 9. The final decision about modifications of the VO schedule and configuration adaptations are up to the VO manager and her negotiation with the other VO members.

The simulation configuration may be divided into two partially independent steps: (i) configuration of the VO state for the beginning of the simulation, and (ii) configuration of the "ifs", i.e. the simulated future. The state of the VO is given by the online operational data collecting tools, or it is defined manually by the VO manager. The simulation future configuration includes definitions and probabilities of the performances deviations (positives as well as negatives), which are represented by (global) *events* and *behavioral models*.

The events do not relate to any particular VO member; they represent situations influencing defined task that occurs out of control of the responsible member. The behavioral models describe the expected will and ability (described by a set of Beta distributions) of the VO members to keep the scheduled dates if participating on any task.

The events and behavioral models may postpone the start of the processing and/or lengthen or shorten it, or they may make the task impossible to be accomplished by the currently

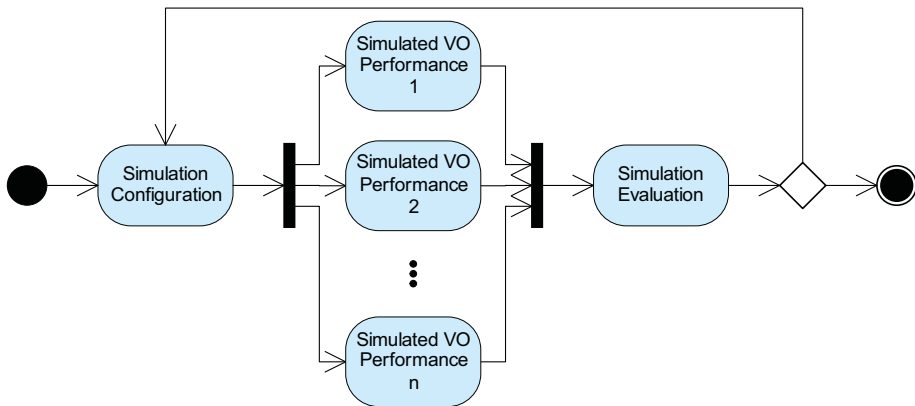

Fig. 9. Activity diagram of the what-if-analysis

responsible member. In such a case, the processing of the task must be negotiated with an alternative member. The events as well as behavioral models are applied to the schedule according to the simulated run of the VO. When the completion time of the task is influenced, the rest of the schedule may be (according to the configuration of the simulation) rescheduled by the right-shift rescheduling or by total rescheduling of the tasks with processing not started yet.

After finishing all simulation runs, the results are collected and mutually compared and evaluated according to the original VO schedule and configuration. The simulation evaluation contains three components: (i) graphic overview of the original schedule together with simulated performances, (ii) various schedule details (e.g. critical path, makespan, and working load) evaluation, and (iii) set of suggestions provided by the simple built-in rule-based system. Examples of the GUI presenting the simulation analysis are in Figure 10.

5.3 DSS verification

The DSS was designed, implemented and verified as a component of the VOM toolkit (all components in form of research prototype) within the ECOLEAD¹² project. The pilot prototype was successfully used in real business environment by Virtuelle Fabrik¹³.

The key features and innovations of DSS are:

- Autonomous agents based modeling (new quality in VO simulation)
 - Each VO member is modeled separately to consider the individuality of the VO members, their behaviors and capabilities.
- Modeling with uncertainty
 - Member's behavioral models based on past performances and experience.
 - Generation of random performance variations allows proving the VO configuration robustness. Statistical simulation based on the Monte-Carlo method
- Integrated prototype (component of the VOM toolkit)
 - Integration allows providing simulation based on the latest VO operational data.

¹² <http://ecolead.vtt.fi/>

¹³ <http://www.virtuelle-fabrik.com>

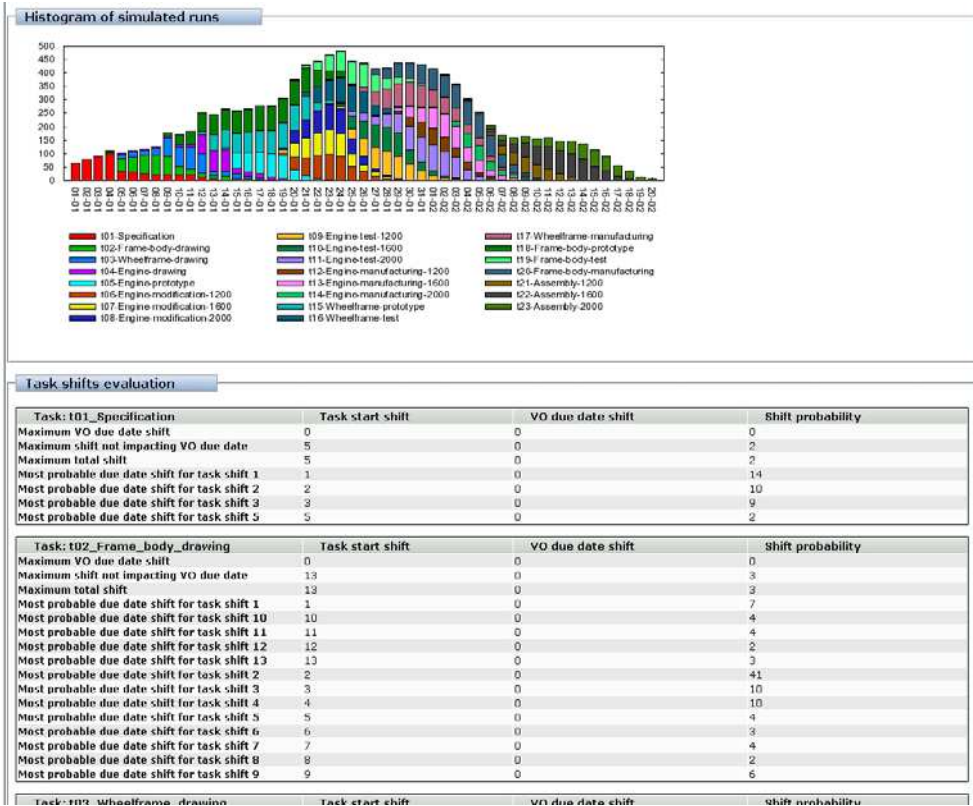

Fig. 10. of user interface for VO simulation evaluation

- Software-as-service implementation (on-demand service)

Users are provided with on-line access to the tools that they could not afford or maintain individually.

6. Conclusion

The three systems presented were created in different times, demonstrating the development of new trends in the decision support systems domain. In the beginning, the systems were focused on aid intra-enterprise decision support and relayed on internal data only.

Later, the cooperation with trusted partners was incorporated. This cooperation required the installation of dedicated software, establishing secure connection between partner's IT systems and, usually, modifications in their business process. These difficulties resulted in a very limited number of systems that were successfully deployed among SMEs.

The contemporary situation is much more favorable for the successful deployment of similar systems. First of all, the systems themselves have evolved - they are more robust, more elaborate and they exploit the research effort of the past years to provide decision support in multiple useful scenarios and to extend their interoperability.

Moreover, the business environment has also changed. SMEs are more aware of the idea of VO and they understand the advantages of cooperation in networked environment. Users are also more accustomed to electronic cooperation and distributed tools. Ideas like software as a service or tools like Google Docs have become part of common business life and largely support the trust in electronic tools.

Future decision support systems will be designed to naturally involve the partners of the company in the decision process. If these partners are part of an alliance, a networked organization or a virtual organization, their data or intentions can be partially obtained using electronic tools and used as an input for decision making. The behavior and intentions of partners, those who are not collaborative enough, can be simulated and used in the decision making as well.

Contemporary technology, which combines centralized and distributed elements, can implement such a system with satisfactory reliability while preserving the partner's independence.

7. Acknowledgements

The ExtraPlanT system has been developed with the support of the EUTIST-AMI IST-2000-28221 project.

Development of voice interface to ExtraPlanT system has been supported by the Ministry of Education of the Czech Republic under Project 1M0567.

Systems e-Cat and VOM (including DSS systems) has been developed with the support of the ECOLEAD project FP6 IP 506958.

The research described is part-funded by the EC FP6 project I*PROMS Network of Excellence and by the Ministry of Education, Youth and Sports of the Czech Republic grant No. MSM 6840770038. The opinions expressed herein are those of the named authors only and should not be taken as necessarily representative of the opinion of the European Commission.

8. References

- Adesta, E. Y. T. (2005). A Strategic Planning Procedure to Support Progress Towards Extended Enterprise. *Proc. of the Eleventh Int. Conf. on Information and Computation Economics ICE-2005* (pp. 371-377). Centre for Concurrent Enterprising.
- Balentine, B.; & Morgan, D. P. (1999). *How to Build a Speech Recognition Application*, Enterprise Integration Group, San Ramon, California, USA
- Bečvář, P.; Pěchouček, M. & Šmídl, L. (2004). Telephony interface of the ExtraPlanT multi-agent production planning system. *Proc. Berliner XML Tage 2004 - Dialogsysteme mit XML-Technologien*, Berlin, Germany
- Bečvář, P.; Šmídl, L.; Pšutka, J. & Pěchouček, M. (2007). An Intelligent Telephony Interface of Multiagent Decision Support Systems. *IEEE Trans. Syst., Man, Cybern. C*, Vol. 37, No. 4, (pp. 553-560)
- Biesalski, E. (2003). Knowledge management and e-human resource management. *FGWM 2003*, Karlsruhe.
- Boughzala, I. & Zacklad, M. (1999). Cooperation engineering for the extended enterprise, *Proceedings of the Human Centered Processes Conference* (pp. 119-127), Brest, France.

- Camarinha-Matos, L. M. & Afsarmanesh, H. (1998). Virtual Enterprises: Life cycle supporting tools and technologies, *Handbook of Life Cycle Engineering: Concepts, Tools and Techniques* (pp. 535-571). Chapman and Hall.
- Friese, T.; Freisleben, B.; Rusitschka, S. & Southall, A. (2002). A Framework for Resource Management in Peer-to-Peer Networks, *Proceedings of NetObjectDays 2002* (pp. 4-21), Springer.
- Hodík, J.; Bečvář, P.; Pěchouček, M.; Vokřínek, J. & Pospíšil, J. (2005) ExPlanTech and ExtraPlanT: multi-agent technology for production planning, simulation and extra-enterprise collaboration. *International Journal of Computer Systems Science & Engineering*, Vol. 20, No. 5 (pp. 357– 367).
- Hodík, J. & Stach J. (2007). Virtual organization simulation for operational management. *Innovative Production Machines and Systems: Third I*PROMS Virtual International Conference*, 2-13 July, 2007. Whittles Publishing, 2007.
- Hodík, J.; Mulder, W.; Pondrelli, L.; Westphal, I. & Hofman, R. (2007). ICT services supporting virtual organization management. *Innovative Production Machines and Systems: Third I*PROMS Virtual International Conference*, 2-13 July, 2007. Whittles Publishing, 2007.
- Hodík, J.; Vokřínek, J. & Bečvář, P. (2009). Support for Virtual Organisation Creation - Partners' Profiles and Competency Management. *International Journal of Agent-Oriented Software Engineering*. Vol. 3, (pp. 230-251). ISSN 1746-1375.
- Mařík, V.; Pěchouček, M.; Štěpánková, O. & Lažanský, J. (2000). ProPlanT: Multi-Agent System for Production Planning. *Applied Artificial Intelligence*, Vol. 14, No. 7
- Matoušek, J.; Romportl, J.; Tihelka D. & Tychtl Z. (2004). Recent Improvements on ARTIC: Czech Text-to-Speech System, *Proceedings of INTERSPEECH 2004 - ICSLP, 8th International Conference on Spoken Language*, Vol. III, pp. 1933–1936, Jeju, Korea
- Miller, J. A.; Cardoso, J. & Silver, G. (2002). Using simulation to facilitate effective workflow adaptation. *SS '02: Proceedings of the 35th Annual Simulation Symposium*, Washington, DC, USA. IEEE Computer Society.
- Müller, J.; Psutka, J. & Šmídl L. (2000). Design of Speech Recognition Engine, In: *Lecture Notes In Computer Science; Vol. 1902; TDS '00: Proceedings of the Third International Workshop on Text, Speech and Dialogue*, (pp. 259–264), Springer-Verlag, London, UK
- Negretto, U.; Hodík, J.; Kral, L.; Mulder, W.; Ollus, M.; Podrelli, L. & Westphal, I. (2008). VO Management Solutions. *Methods and Tools for Collaborative Networked Organizations*. Heidelberg: Springer.
- Neubert, R.; Langer, O.; Görlitz, O. & Benn, W. (2001). Virtual enterprises-challenges from a database perspective. *ITVE '01: Proceedings of the IEEE workshop on Information technology for Virtual Enterprises*, (pp. 98-106), Washington, DC, USA. IEEE Computer Society.
- Pěchouček, M.; Mařík, V. & Bárta, J. (2002a). A knowledge-based approach to coalition formation. *IEEE Intelligent Systems*, , Vol. 17, No. 3, (pp. 17–25).
- Pěchouček, M.; Říha, A; Vokřínek, J.; Mařík, V. & Pražma, Ř. (2002b). ExPlanTech: applying multi-agent systems in production planning. *International Journal of Production Research*, Vol. 40, No. 15, (pp. 3681–3692)
- Pěchouček, M.; Vokřínek, J. & Bečvář, P. (2005). ExPlanTech: Multiagent Support for Manufacturing Decision Making. *IEEE Intell. Syst.* Vol. 20, No. 1, (pp. 67–74)

- Říha, A.; Pěchouček, M.; Vokřínek, J. & Mařík, V. (2002). From intra-enterprise towards extra-enterprise production planning, *Knowledge and Technology Integration in Production and Services* (pp. 349–356). New York, Kluwer Academic / Plenum Publishers.
- Shen, W.; Lang, S. & Wang, L. (2005). iShopFloor: an Internet-enabled agent-based intelligent shop floor. *IEEE Trans. Syst., Man, Cybern. C*, Vol. 35, No. 3, (pp. 371–381)
- Šmídl, L.; Müller, L. & Psutka, J. (2002). VoiceXML Based Telephone Dialog System Providing Access to Entrance Examination Results Stored in the University Database, *Proc. SCI 2002, Orlando, July 2002*

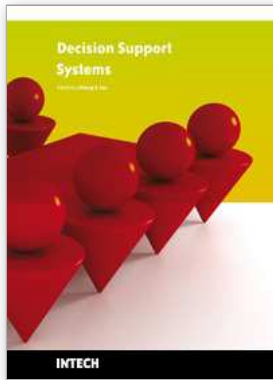

Decision Support Systems

Edited by Chiang S. Jao

ISBN 978-953-7619-64-0

Hard cover, 406 pages

Publisher InTech

Published online 01, January, 2010

Published in print edition January, 2010

Decision support systems (DSS) have evolved over the past four decades from theoretical concepts into real world computerized applications. DSS architecture contains three key components: knowledge base, computerized model, and user interface. DSS simulate cognitive decision-making functions of humans based on artificial intelligence methodologies (including expert systems, data mining, machine learning, connectionism, logistical reasoning, etc.) in order to perform decision support functions. The applications of DSS cover many domains, ranging from aviation monitoring, transportation safety, clinical diagnosis, weather forecast, business management to internet search strategy. By combining knowledge bases with inference rules, DSS are able to provide suggestions to end users to improve decisions and outcomes. This book is written as a textbook so that it can be used in formal courses examining decision support systems. It may be used by both undergraduate and graduate students from diverse computer-related fields. It will also be of value to established professionals as a text for self-study or for reference.

How to reference

In order to correctly reference this scholarly work, feel free to copy and paste the following:

Petr Bečvář, Jiří Hodík, Michal Pěchouček, Josef Psutka, Luboš Šmídl and Jiří Vokřínek (2010). Expanding Decision Support Systems Outside Company Gates, Decision Support Systems, Chiang S. Jao (Ed.), ISBN: 978-953-7619-64-0, InTech, Available from: <http://www.intechopen.com/books/decision-support-systems/expanding-decision-support-systems-outside-company-gates>

INTECH

open science | open minds

InTech Europe

University Campus STeP Ri
Slavka Krautzeka 83/A
51000 Rijeka, Croatia
Phone: +385 (51) 770 447
Fax: +385 (51) 686 166
www.intechopen.com

InTech China

Unit 405, Office Block, Hotel Equatorial Shanghai
No.65, Yan An Road (West), Shanghai, 200040, China
中国上海市延安西路65号上海国际贵都大饭店办公楼405单元
Phone: +86-21-62489820
Fax: +86-21-62489821